

# PRODUCT MANUAL

*Sections 10-15*

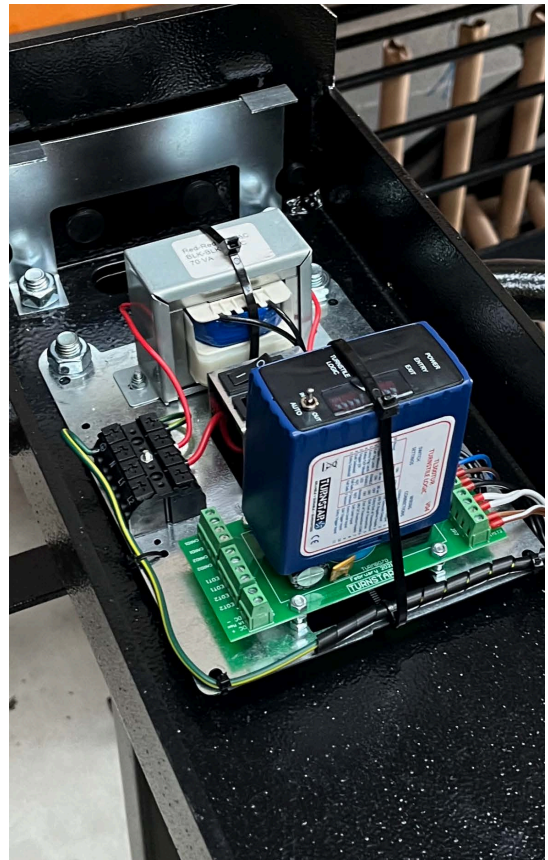

## FULL HEIGHT TURNSTILE

*Control Head Mechanism*

## 10. **CONTROL PANEL & LOGIC**

- 10.1. The control panel consists of a 220v AC power connection terminal, leading to an isolator. The isolator leads to an 18VAC transformer (sometimes 19V or battery backup) which distributes power to the printed circuit board and the plug-in logic. All the components are mounted onto a pre-galvanised chassis plate.
- 10.2. The plug-in logic controls the functions of the turnstile. (The logic may differ from the image shown. See Section 11.

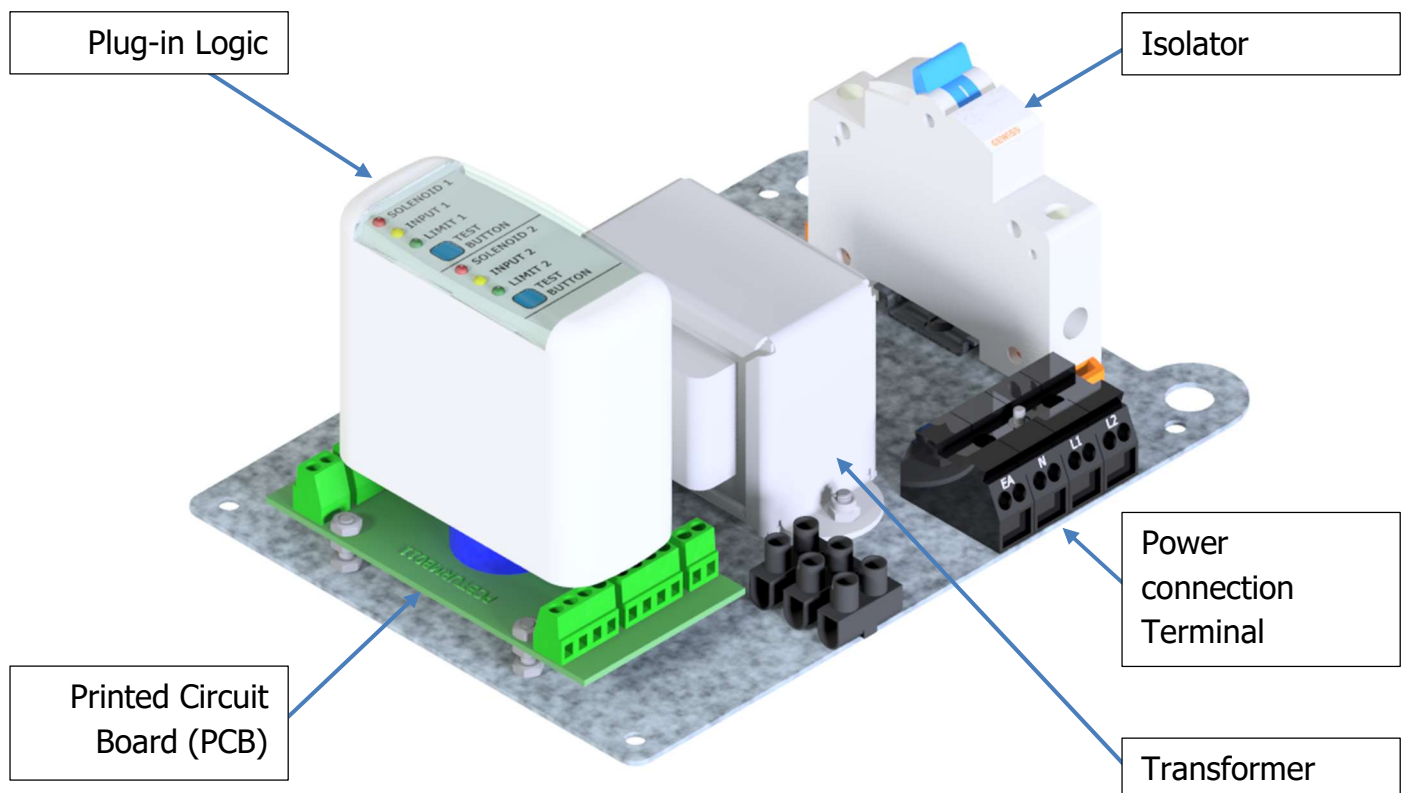

**Figure 24: Turnstile control panel components**

- 10.3. The trigger inputs on the logic are activated by a potential free contact (dry contact).
- 10.4. The limit switch inputs on the logic are activated by a potential free contact (dry contact).
- 10.5. The solenoid outputs on the logic are solid state MOSFET rated at 1,5A / 24VDC.
- 10.6. The EOT (End of transaction) outputs on the logic are normally open relays rated at 0,5A / 24 VDC.

## 11. TURNSTILE LOGIC TYPES

11.1. The control panel may be using one of two plug-in logics. Both logics have the same operation and features and are interchangeable. The grey logic (TURTL373) is mainly used locally in South-Africa and neighbouring countries. The blue logic (TL300TUR) is mainly used for exports to other countries.

11.2. The face of the logic incorporates two blue test buttons and six diagnostic LED indicators.

11.3. To test the grey logic, press one of the test buttons briefly.

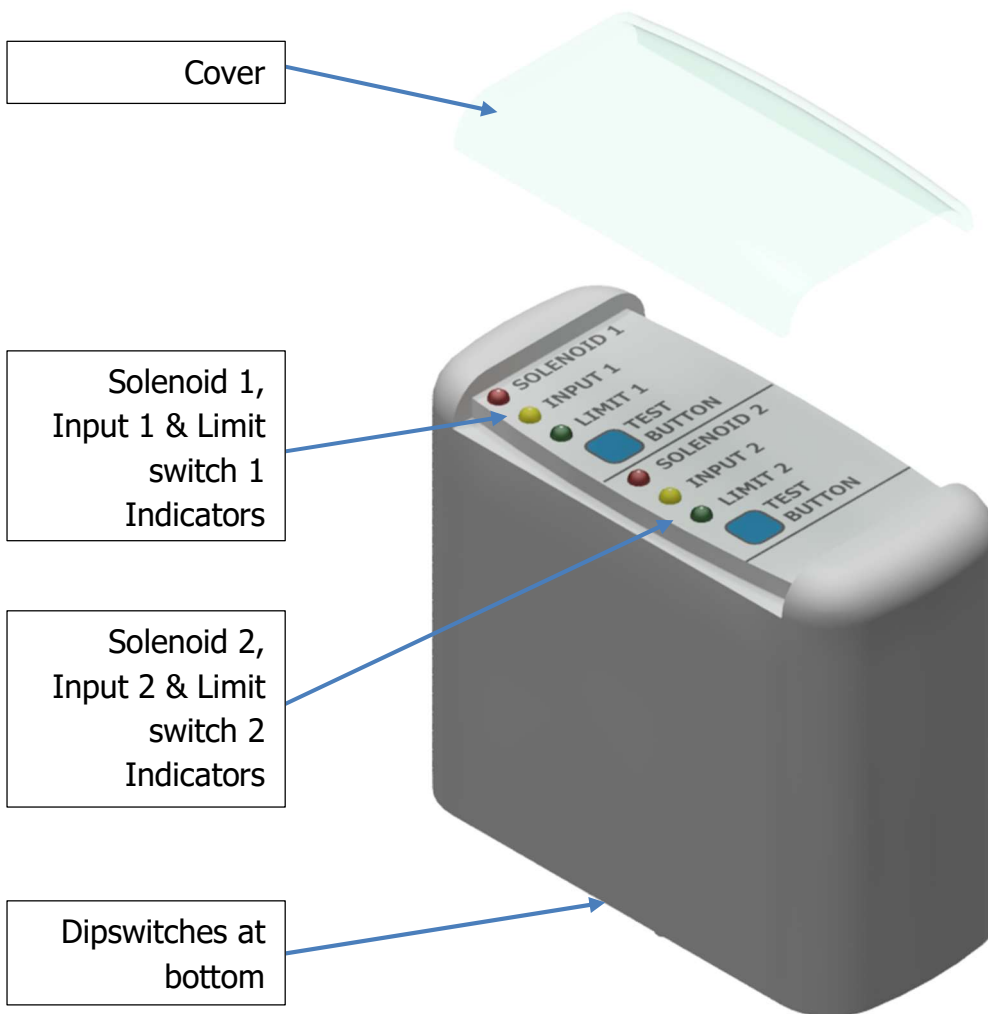

**Figure 25: Grey Plug-in Logic (TURTL373)**

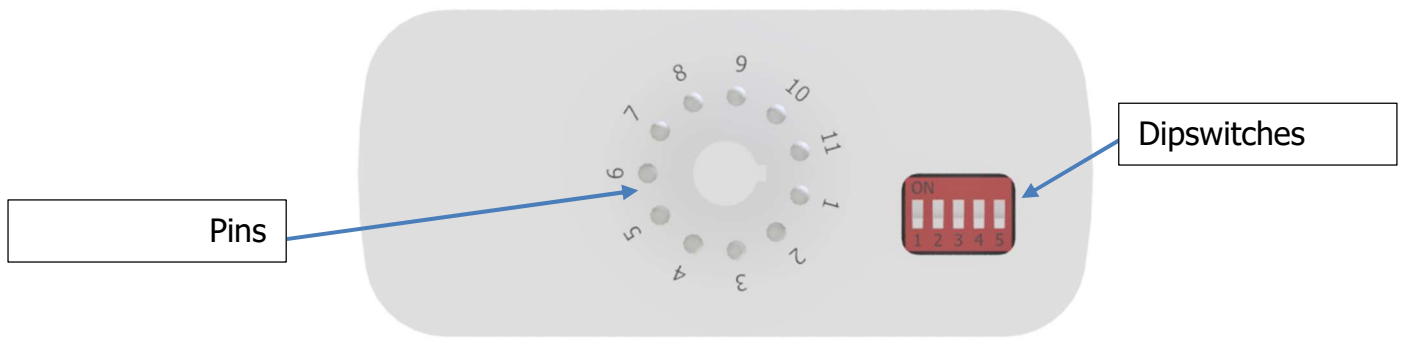

**Figure 26: Base of Grey Plug-in Logic (TURTL373)**

**Table 1: TURTL373 Logic Dipswitch Settings**

Switch No.	Function	ON	OFF
5	Sound	On	Off
4	Solenoid 2	Fail-Secure	Fail-Safe
3	Solenoid 1	Fail-Secure	Fail-Safe
2	Input 2 (Direction 2) (Fire Alarm)	Extended Trigger	Once-off Trigger
1	Input 1 (Direction 1) (Fire Alarm)	Extended Trigger	Once-off Trigger

11.4. The blue logic (TL300TUR) has a section showing feedback LED, dipswitches under a flip-open cover and a toggle switch for testing. The feedback section shows when the logic has power, when an entry trigger is received and when an exit trigger is received. The toggle switch must always be in the centre for automatic mode.

11.5. To test the grey logic, flip the toggle switch briefly to either 'in' or 'out' and return it to the centre.

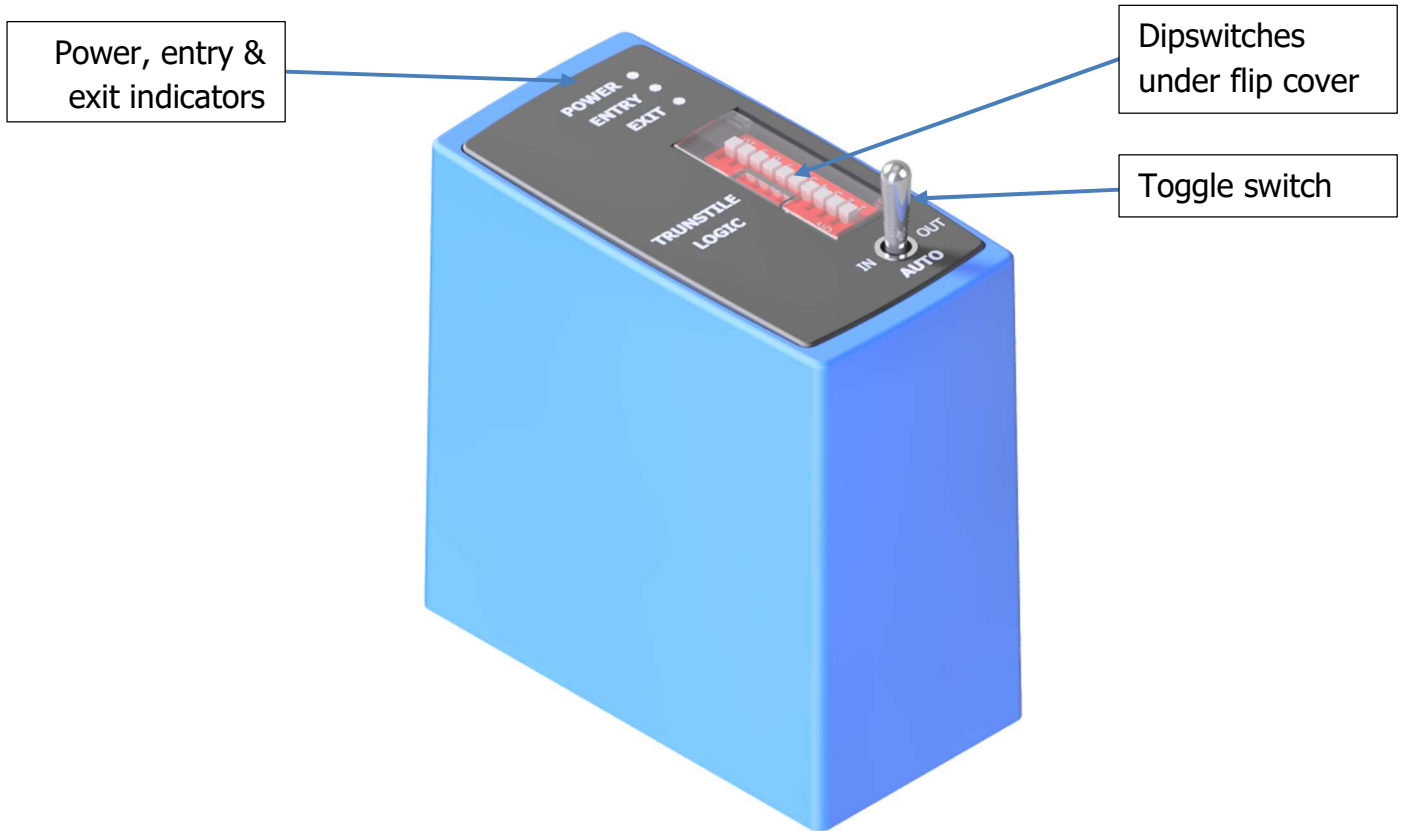

**Figure 27: Blue Plug-in Logic (TL300TUR)**

**Table 2: TL300TUR Logic Dipswitch Settings**

Switch No.	Function	ON	OFF
10	Not used	Reset	Off
9	Not used	-	Off
8	Timeout	10 Sec.	20 Sec.
7	Trigger memory	On	Off
6	Exit trigger latch	Enable	Off
5	Entry trigger latch	Enable	Off
4	Relay output mode	LED / Buzzer mode	Transaction Complete Mode
3	Entry/ Exit trigger input	N/C	N/O
2	Exit Solenoid	Fail Safe	Fail Secure
1	Entry Solenoid	Fail Safe	Fail Secure

## 12. WIRING DIAGRAMS

12.1. The control panel consists of a 220v AC power connection terminal, leading to an isolator. The isolator leads to the transformer which distributes 18VAC power to the printed circuit board and the plug-in logic. All the components are mounted to a pre-galvanised plate.

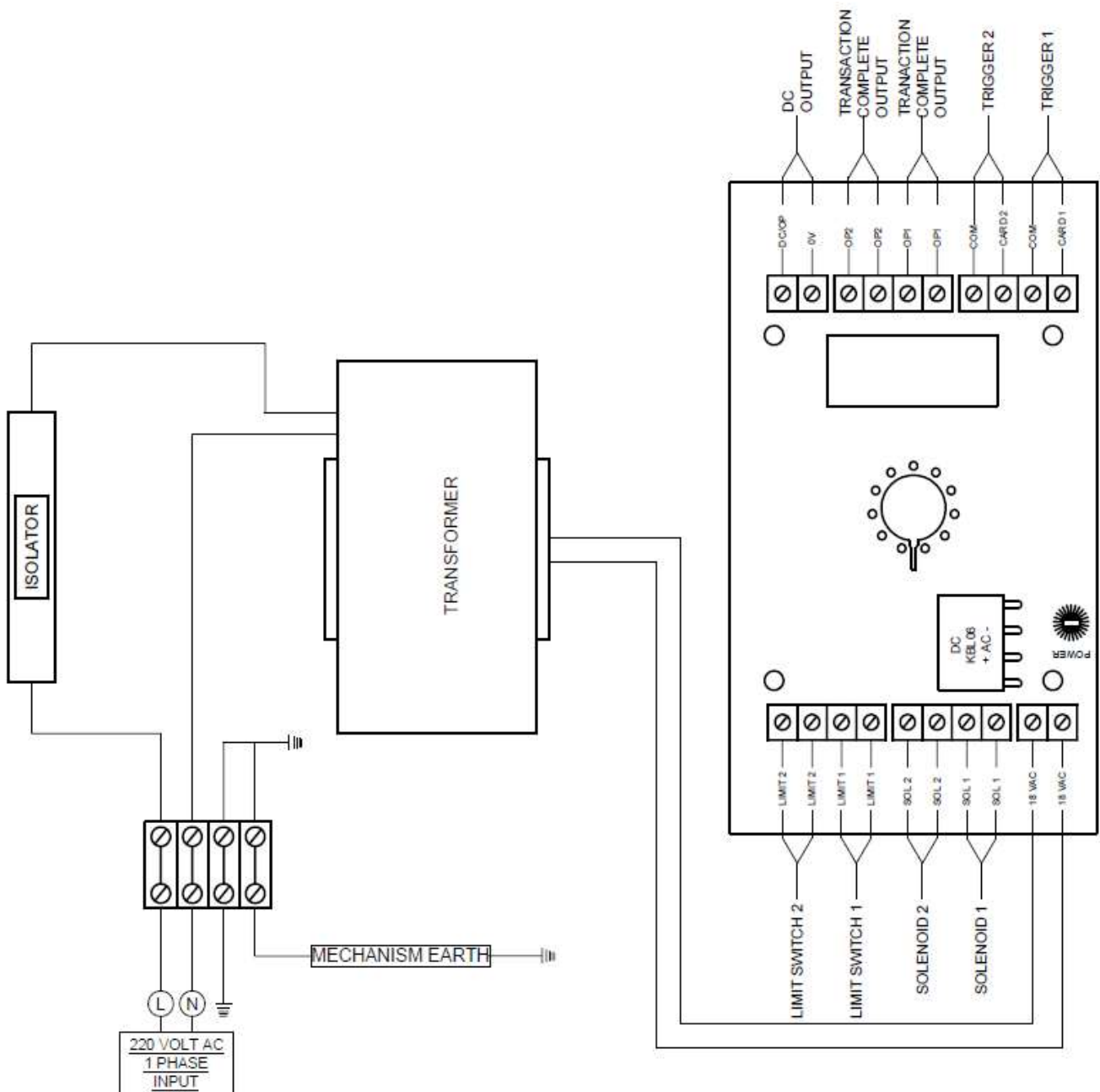

**Figure 28: Wiring Diagram for Full Height Turnstile**

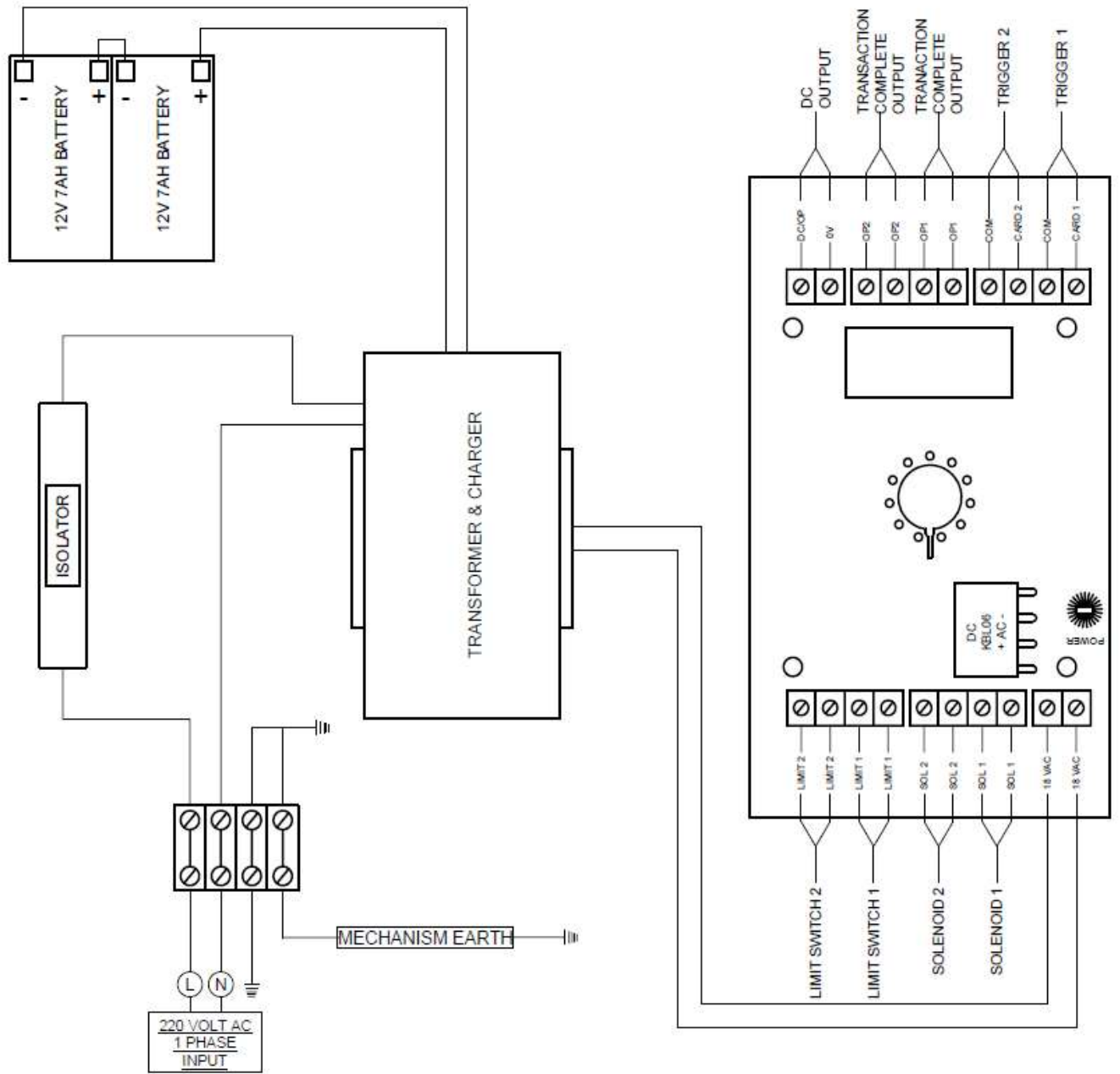
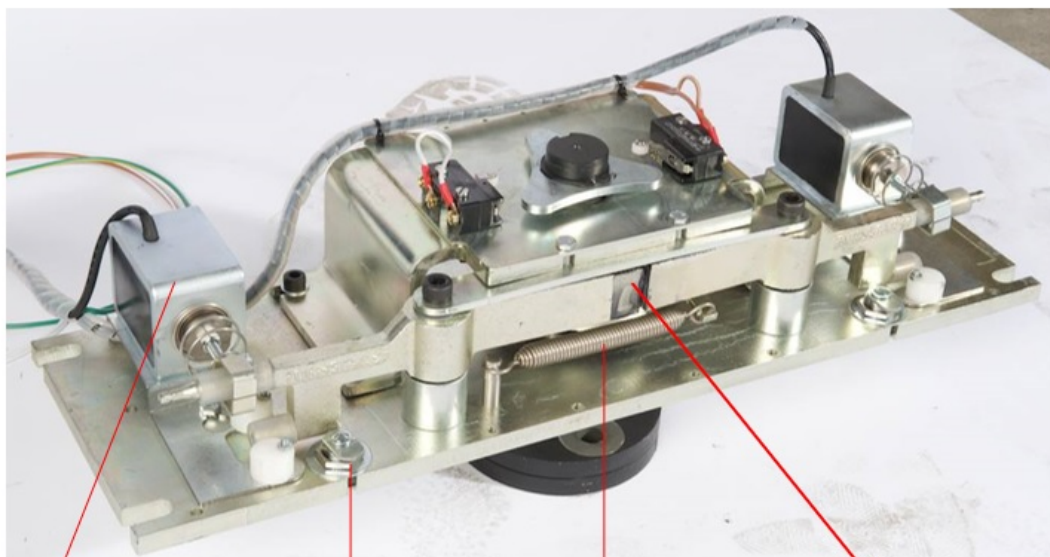

**Figure 29: Wiring Diagram for FH Turnstile with Battery Backup**



### 13. **STANDARD FACTORY SETUP**

- 13.1. Ensure mains power is switched off.
- 13.2. Connect the mains power cable to the turnstile controller at the power connection terminal.
- 13.3. Connect the access control relay output to the triggers on the PCB (Trigger 1 and Trigger 2), one for each direction. The trigger to unlock the turnstile is a dry-contact, potential free input. The closing signal should be no longer than 0,5 seconds.
- 13.4. Switch on the mains power.
- 13.5. Check that mains power is being distributed to the control board.
- 13.6. Test the turnstile unlocking by triggering the access control system. Confirm the direction that is being opened is correct as required by the access control. If it is not, swap the trigger inputs on the control panel.
- 13.7. When triggering, walk through the turnstile. When exiting, the turnstile rotor will lock, not allowing further entry. Repeat this for the opposite direction.
- 13.8. If the turnstile does not trigger from the access control system, test the logic using the button or toggle provided.



Solenoid

Mechanical key  
override lock

Indexing  
spring

Locking disk



## 14. **FIRE ALARM SET-UP**

- 14.1. If the grey logic is used (TURTL373), ensure dipswitches 1 & 2 is switched **ON**. When giving an extended trigger to either trigger 1 or trigger 2 from the access control, the turnstile will be open, and any number of pedestrians can pass through. The turnstile will remain open until the extended trigger is removed.
- 14.2. If the blue logic is used (TL300TUR), ensure dipswitches 6 and 7 is switched **ON**. When giving an extended trigger to either trigger 1 or trigger 2 from the access control, the turnstile will be open, and any number of pedestrians can pass through. The turnstile will remain open until the extended trigger is removed.

## 15. **FAIL-SECURE AND FAIL-SAFE**

- 15.1. The turnstile mechanism can be configured either in fail-safe or fail-secure. The default factory setting is fail-secure.
- 15.2. A fail-safe mechanism configuration unlocks the rotor to freely rotate in the case of a power-failure.
- 15.3. A fail-secure mechanism configuration locks the rotor in case of power failure. In this case, if the rotor is required to be unlocked, this can be done by unlocking the mechanical over-ride with the key provided.



**Figure 30: Solenoid in Fail-secure arrangement**

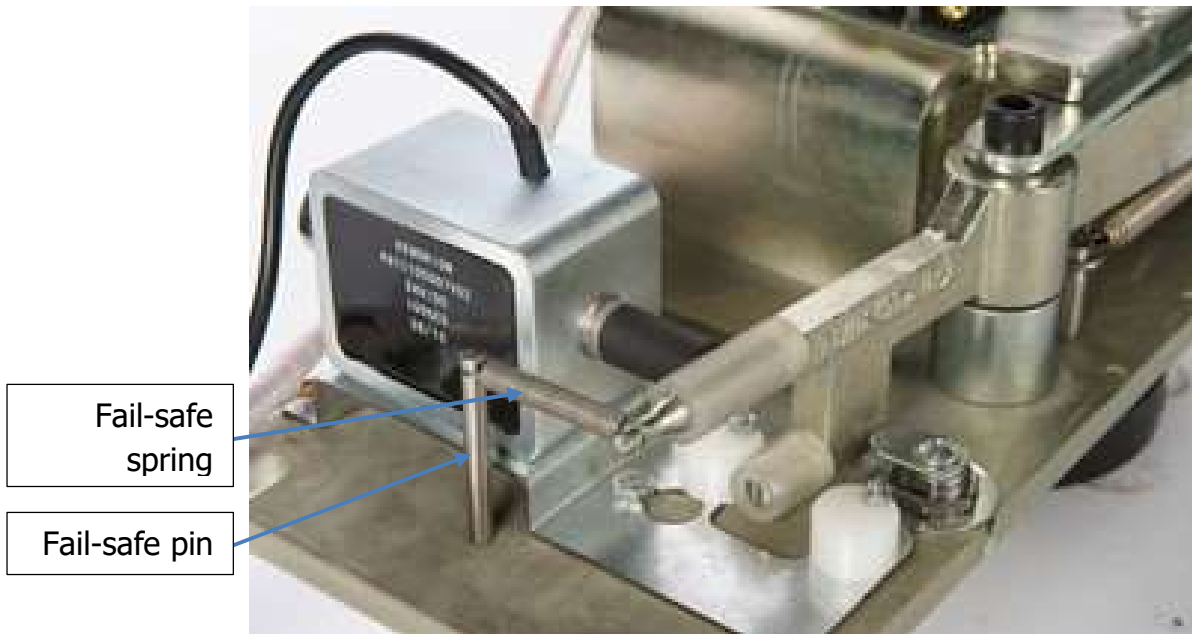

**Figure 31: Solenoid in Fail-safe arrangement**

15.4. If fail-safe, a solenoid is 'pushing' on the pawl when under power. When in fail-secure, a solenoid is pulling when under power.

15.5. For **Fail-Secure** setting, on the logics,

- Grey Logic (TURTL373) – Ensure dipswitches 2 and 3 are **ON**.
- Blue Logic (TL300TUR) – Ensure dipswitches 1 and 2 are **OFF**.

15.6. For **Fail-Safe** setting, on the logics,

- Grey Logic (TURTL373) – Ensure dipswitches 2 and 3 are **OFF**.
- Blue Logic (TL300TUR) – Ensure dipswitches 1 and 2 are **ON**.

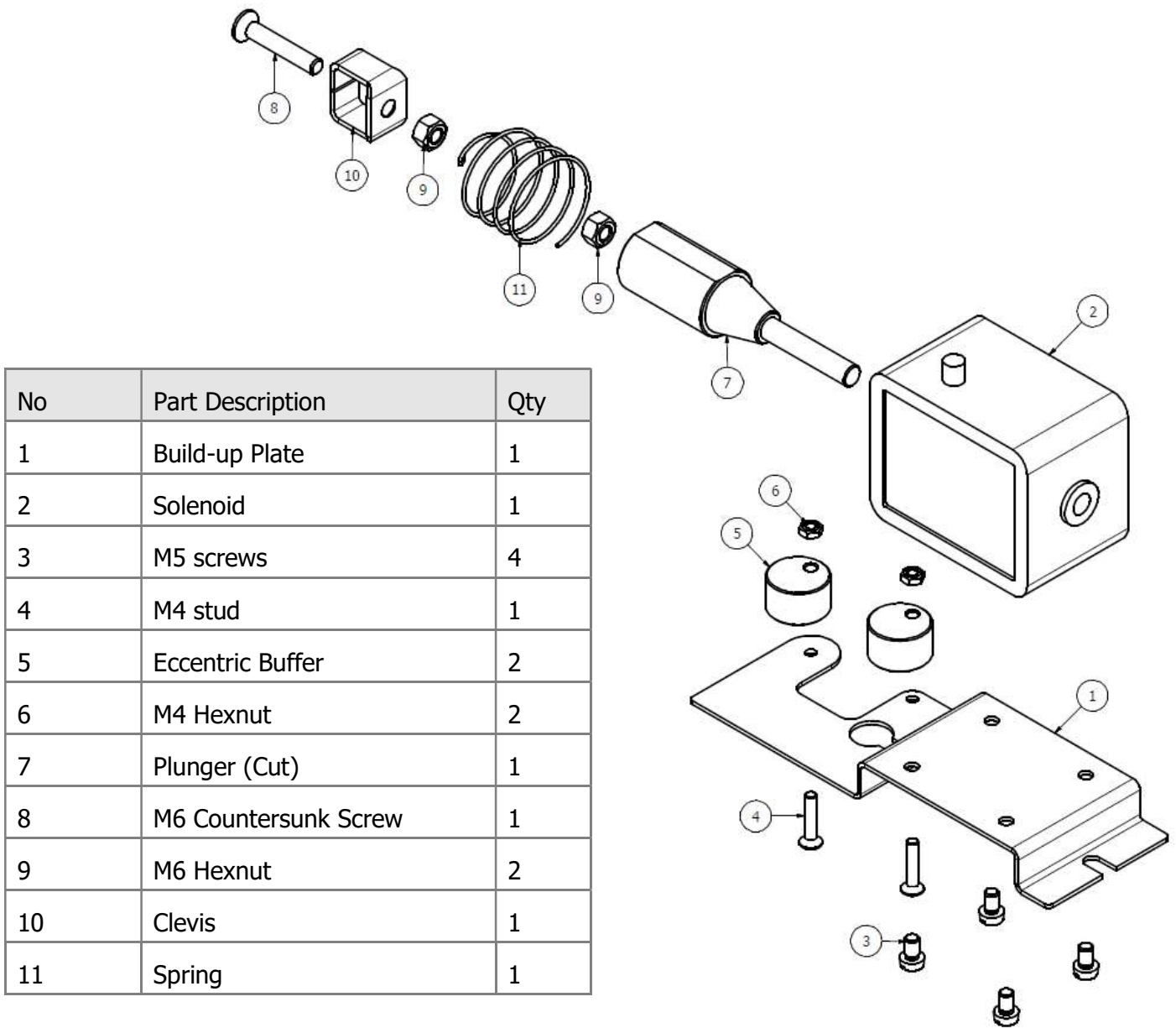

No	Part Description	Qty
1	Build-up Plate	1
2	Solenoid	1
3	M5 screws	4
4	M4 stud	1
5	Eccentric Buffer	2
6	M4 Hexnut	2
7	Plunger (Cut)	1
8	M6 Countersunk Screw	1
9	M6 Hexnut	2
10	Clevis	1
11	Spring	1

**Figure 32: Solenoid assembly – Fail-secure**

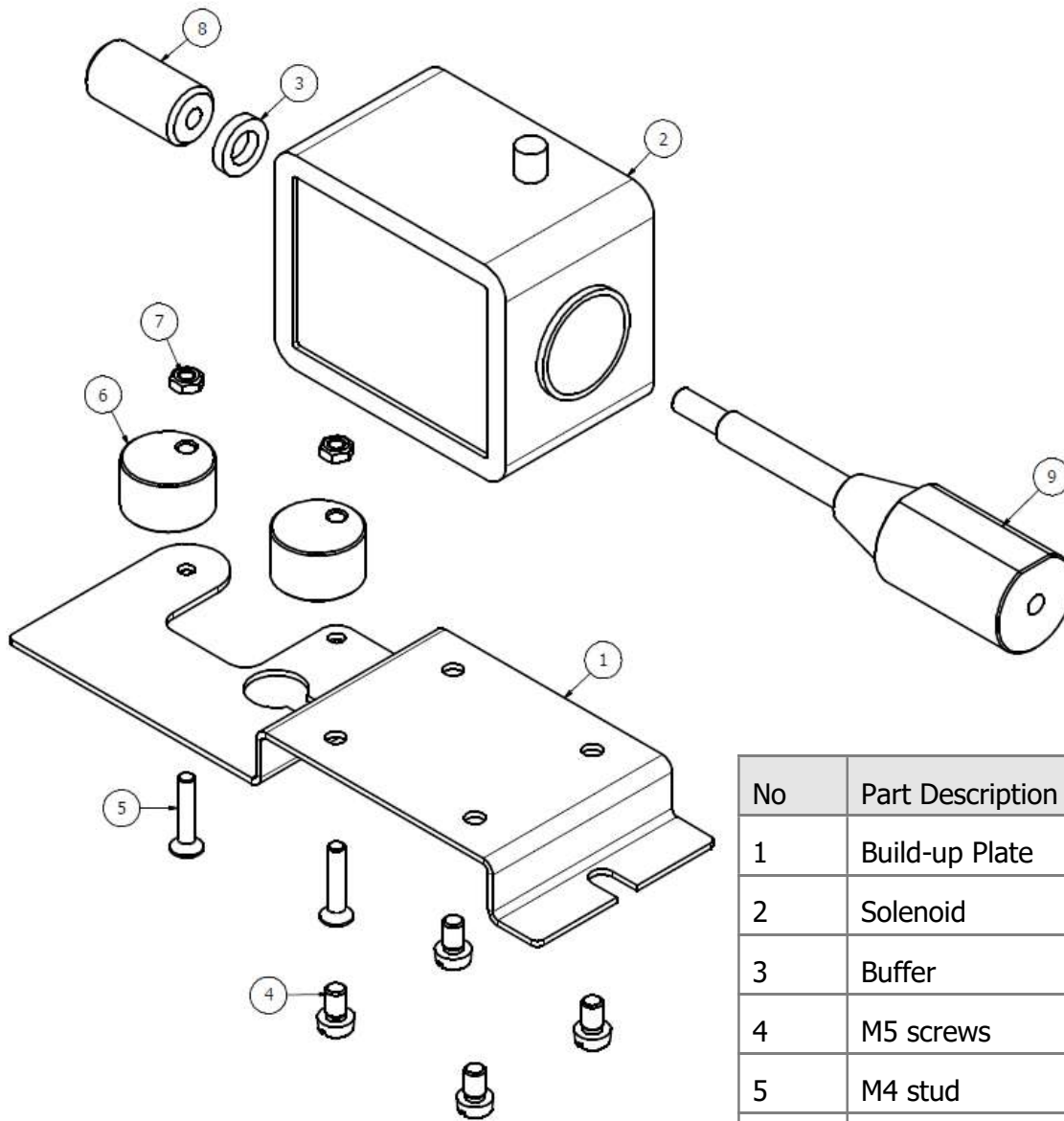

No	Part Description	Qty
1	Build-up Plate	1
2	Solenoid	1
3	Buffer	1
4	M5 screws	4
5	M4 stud	1
6	Eccentric Buffer	2
7	M6 Hexnut	2
8	Cam	1
9	Plunger	2

Note, when placing the fail-safe solenoid build up, also install the fail-safe pin and spring to the pawl, shown in Figure 31.

**Figure 33: Solenoid assembly – Fail-safe**